

VendTag User Handbook V1.0

This booklet contains technical information including wiring diagrams and application examples

1. General operation
2. Control of user keys
3. Application example: Simple vending machine (VMC) interface through coin validator connector
4. Application example: Relay output in pulsed mode
5. Application example: Relay output in latched mode
6. Application example: Access control for security doors, turnstiles, car park barriers, etc.

1. General Operation

Red User Tags

The VendTag system allows users to receive a limited or unlimited number of vends per day. Each tag may be individually set to give 1 to 9 vends per day or unlimited vends.

In normal use the VendTag display shows either a flashing dot to show it is operational or a dash to show it is inhibited by a signal into the Inhibit/Reset input.

When the user touches a tag on the sensor, the display shows number of vends remaining on the key. If the key is for unlimited vends then the display shows "F" for "free".

If the tag is held on the sensor for two seconds a vend is taken from the tag. The VendTag output can be a pulse on any of the six coin validator lines or the built in relay can pulse or latch. In Latching mode the relay is unlatched by a signal into the VendTags inhibit/reset input.

Blue Master Tag

The Master Tag allows the following functions

- a. Add more user keys to the system
- b. Determine the daily limit for each key
- c. Erase all user keys

VendTag simple connection using Coin Validator connections only

The VendTag is powered from the coin validator cable and monitors the coin inhibit line to prevent vends being taken from a key when the coin validator is inhibited. The output pulse may be on any of the coin lines.

- Jp1 = output pulse on coin 5
- Jp2 = output pulse on coin 6
- Jp3 = output pulse on coin 1
- Jp4 = output pulse on coin 2
- Jp5 = output pulse on coin 3
- Jp6 = output pulse on coin 4

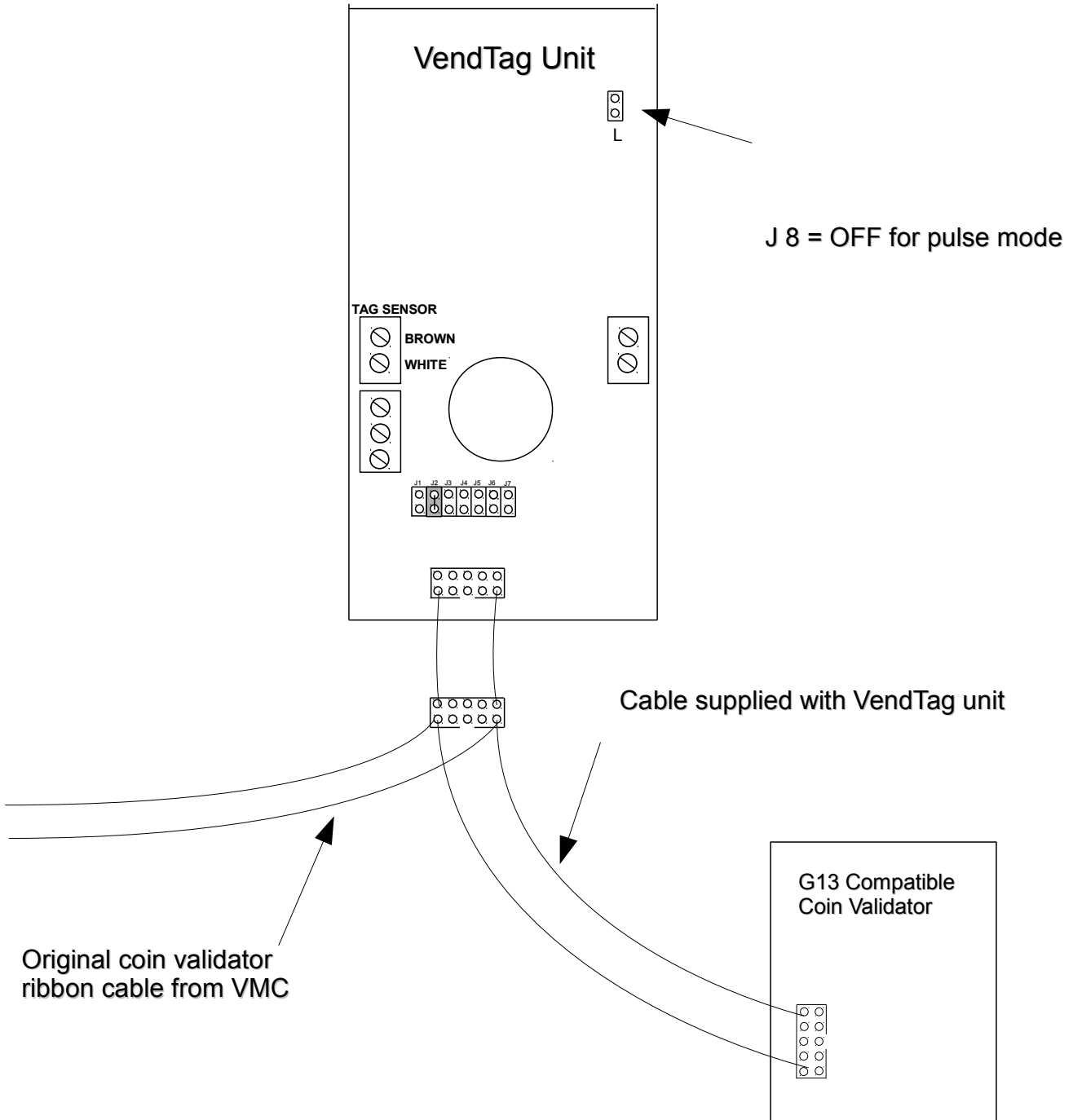

Note. This arrangement also would work in latched output mode (J8 fitted) if the coin validator is inhibited by the VMC during the vend. The relay will unlatch at the end of the vend when the validator is enabled again. This could be useful if the VendTag relay output was wired across free vend switch on the VMC which needed to stay switched on until the end of the vend.

VendTag connection using the internal relay output in Pulse Mode

The VMC owner needs to provide a 12 Volt supply to the VendTag. The output pulse is from voltage free relay contacts. The optional inhibit input when taken to 0V prevents vend being taken from a tag, for instance when the machine is busy or sold out.

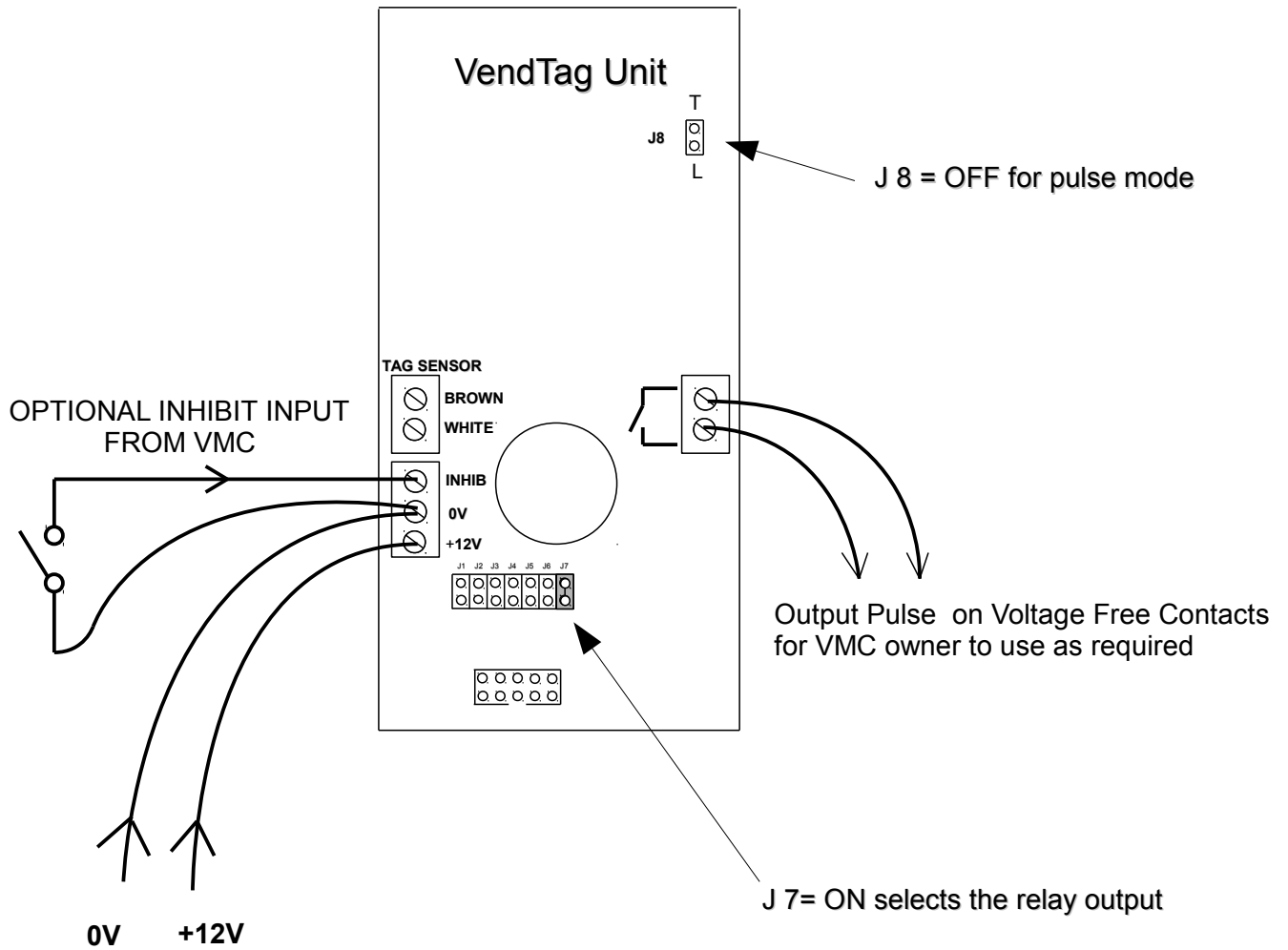

12V Power Supply to Vend Tag Unit

VendTag connection using the internal relay output in Latch Mode

The VMC owner needs to provide a 12 Volt supply to the VendTag. The output pulse is from voltage free relay contacts.

The output relay latches until the Reset input is taken to 0V. This input may also be used to inhibit the VendTag by holding the input low for instance when the machine is busy or sold out.

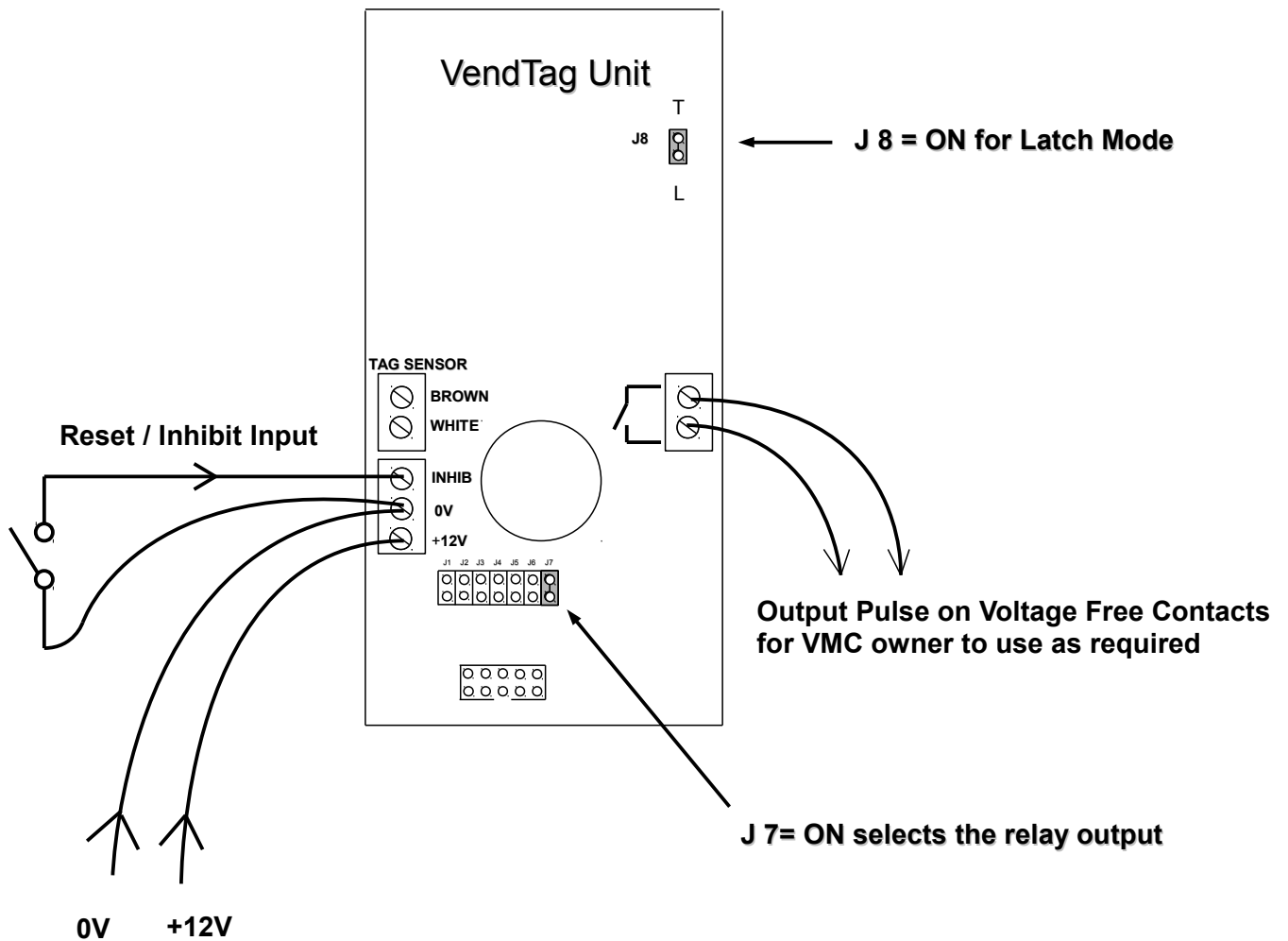

12V Power Supply to VendTag Unit

Access control for Security Doors, Turnstiles, Car Park Barriers, etc.

